

CROWN

Jehs+Laub

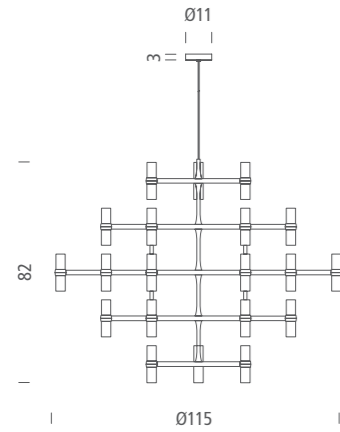

Famiglia di chandelier a sospensione, realizzata con una struttura modulare in alluminio pressofuso e bicchierini diffusori in vetro sabbato. La struttura è disponibile in versione alluminio spazzolato a mano lucido, dorato oppure verniciato opaco nei colori bianco, nero o oro. E' disponibile un kit LED G9 NEMO. La lampada emette una luce diffusa. Doppia accensione nella versione SUMMA. Cavo trasparente, rosso su richiesta.

Pendant chandeliers, with modular structure in die-casted aluminium and sandblasted glass diffusers. Structure in aluminium hand polished, glossy gold plated or painted in matt white, matt black or gold. Available a NEMO LED G9 kit. Widespread light. Double switch for the SUMMA version. Transparent cable. Red cable on request.

Famille de chandeliers à suspension, réalisée avec une structure modulaire en aluminium moulé. Diffuseurs en verre sablé. Disponible en aluminium poli à la main brillant ou or ou peint en blanc mat, noir mat ou or. Kit LED NEMO G9 lumière chaude disponible. Lumière diffuse. Double interrupteur dans la version SUMMA. Câble transparent (rouge sur demande).

Familie von Kronleuchtern mit einer modularen Struktur aus Aluminiumdruckguß und sandgestrahlten Diffusorgläsern. Die Struktur ist glänzend poliert und vergoldet sowie in matt weiß, matt schwarz und goldfarben lackiert lieferbar. NEMO liefert Ihnen auch ein G9-Set LED mit warmer Lichtausstrahlung. Die Leuchte hat eine diffuse Lichtstreuung. Ausführungen SUMMA doppelt schaltbar. Transparentes Kabel, rotes Textilkabel auf Anfrage.



CROWN MAJOR PENDANT HALO/LED

| | |
|-----------|---|
| source | halopin G9 QT-14 |
| emission | diffused |
| max power | 30x25W |
| switching | dimmmable according to bulb |
| tension | 110/230V |
| note | cable lenght max 3,5m, LED version with kit G9 LED NEMO (p.269) |

| FINISHING | code | structure |
|-------------|------------|-----------|
| white | CRO HWT 52 | ○ |
| polished | CRO HLT 52 | ● |
| black | CRO HNT 52 | ● |
| gold | CRO HGW 52 | ● |
| gold plated | CRO HOW 52 | ● |



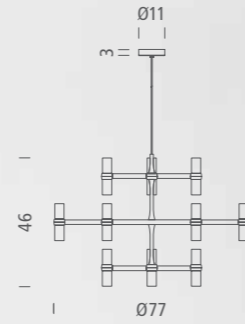

**CROWN MINOR
PENDANT HALO/LED**

| | |
|-----------|---|
| source | halopin G9 QT-14 |
| emission | diffused |
| max power | 12x25W |
| switching | dimmable according to bulb |
| tension | 110/230V |
| note | cable lenght max 2,5m, LED version with kit G9 LED NEMO (p.269) |

| FINISHING | code | structure |
|-------------|------------|-----------|
| white | CRO HWT 51 | ○ |
| polished | CRO HLT 51 | ● |
| black | CRO HNT 51 | ● |
| gold | CRO HGW 51 | ● |
| gold plated | CRO HOW 51 | ● |

CROWN MINOR GOLD PLATED

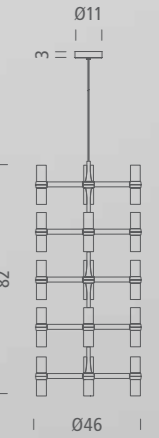

**CROWN MULTI
PENDANT HALO/LED**

| | |
|-----------|---|
| source | halopin G9 QT-14 |
| emission | diffused |
| max power | 15x25W |
| switching | dimmable according to bulb |
| tension | 110/230V |
| note | cable lenght max 2,5m, LED version with kit G9 LED NEMO (p.269) |

| FINISHING | code | structure |
|-------------|------------|-----------|
| white | CRO HWW 58 | ○ |
| polished | CRO HLW 58 | ● |
| black | CRO HNW 58 | ● |
| gold | CRO HGW 58 | ● |
| gold plated | CRO HOW 58 | ● |

CROWN MULTI WHITE



CROWN SUMMA POLISHED AT GALLERIA RIZZOLI MILAN

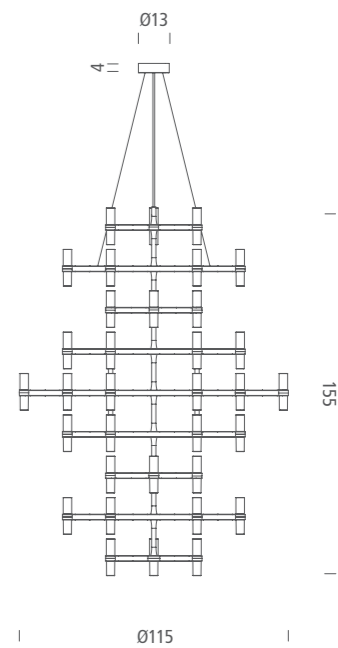

**CROWN SUMMA
PENDANT HALO/LED**

source halopin G9 QT-14
 emission diffused
 max power 48x25W
 switching double, dimmable according to bulb
 tension 110/230V
 note cable lenght max 3,5m, LED version with kit G9 LED NEMO (p.269)

| FINISHING | code | structure |
|-------------|------------|-----------|
| white | CRO HWW 59 | ○ |
| polished | CRO HLW 59 | ● |
| black | CRO HNW 59 | ● |
| gold | CRO HGW 59 | ● |
| gold plated | CRO HOW 59 | ● |



CROWN MAGNUM AT HOTEL BAYERISCHER HOF LINDAU / ARCH. EBWERT & STÖTTLE / KLAUS SPORER

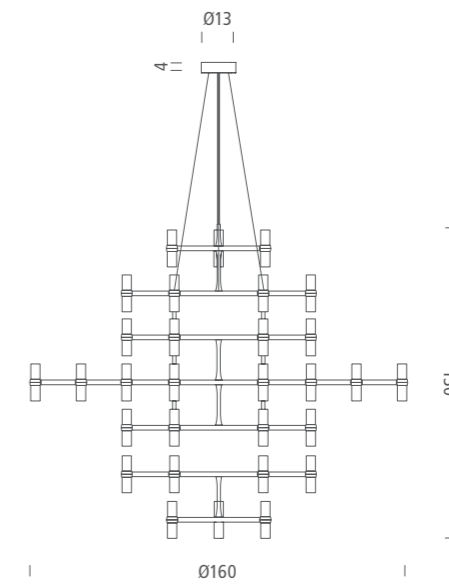

**CROWN MAGNUM
PENDANT LED**

| | |
|-----------|--|
| source | LED G9 |
| emission | diffused |
| max power | 42x3W |
| switching | dimmable according to bulb |
| tension | 110/230V |
| note | cable lenght max 3,5m, only LED version with kit G9 LED NEMO (p.269) |

| FINISHING | code | structure |
|-------------|------------|-----------|
| white | CRO HWW 5A | ○ |
| polished | CRO HLW 5A | ● |
| black | CRO HNW 5A | ● |
| gold | CRO HGW 5A | ● |
| gold plated | CRO HOW 5A | ● |





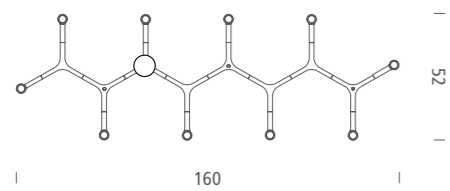

**CROWN PLANA LINEA
PENDANT HALO/LED**

source halopin G9 QT-14
 emission diffused
 max power 10x25W
 switching dimmable according to bulb
 tension 110/230V
 note cable lenght max 2,5m, LED version with kit G9 LED NEMO (p.269)

| FINISHING | code | structure |
|-------------|------------|-----------|
| white | CRO HWW 54 | ○ |
| polished | CRO HLW 54 | ● |
| black | CRO HNW 54 | ● |
| gold | CRO HGW 54 | ● |
| gold plated | CRO HOW 54 | ● |

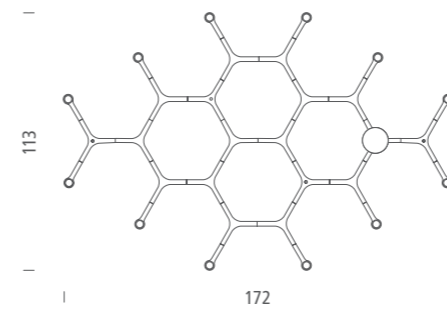

**CROWN PLANA MEGA
PENDANT HALO/LED**

source halopin G9 QT-14
 emission diffused
 max power 12x25W
 switching dimmable according to bulb
 tension 110/230V
 note cable lenght max 2,5m, LED version with kit G9 LED NEMO (p.269)

| FINISHING | code | structure |
|-------------|------------|-----------|
| white | CRO HWW 57 | ○ |
| polished | CRO HLW 57 | ● |
| black | CRO HNW 57 | ● |
| gold | CRO HGW 57 | ● |
| gold plated | CRO HOW 57 | ● |



CROWN GOLD PLATED



CROWN POLISHED

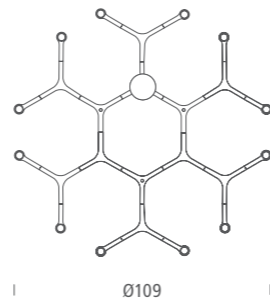
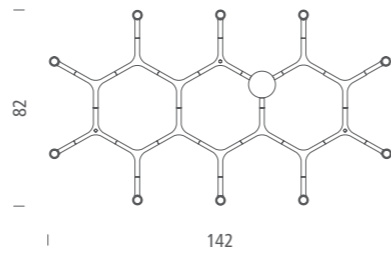
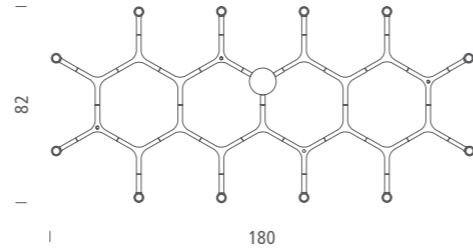

**CROWN PLANA MAJOR
PENDANT HALO/LED**

source halopin G9 QT-14
 emission diffused
 max power 12x25W
 switching dimmable according to bulb
 tension 110/230V
 note cable lenght max 2,5m,
 LED version with kit
 G9 LED NEMO (p.269)

| FINISHING | code | structure |
|-------------|------------|-----------|
| white | CRO HWW 53 | ○ |
| polished | CRO HLW 53 | ● |
| black | CRO HNW 53 | ● |
| gold | CRO HGW 53 | ● |
| gold plated | CRO HOW 53 | ● |

**CROWN PLANA
PENDANT HALO/LED**

source halopin G9 QT-14
 emission diffused
 max power 10x25W
 switching dimmable according to bulb
 tension 110/230V
 note cable lenght max 2,5m,
 LED version with kit
 G9 LED NEMO (p.269)

| FINISHING | code | structure |
|-------------|------------|-----------|
| white | CRO HWW 56 | ○ |
| polished | CRO HLW 56 | ● |
| black | CRO HNW 56 | ● |
| gold | CRO HGW 56 | ● |
| gold plated | CRO HOW 56 | ● |

**CROWN PLANA MINOR
PENDANT HALO/LED**

source halopin G9 QT-14
 emission diffused
 max power 12x25W
 switching dimmable according to bulb
 tension 110/230V
 note cable lenght max 2,5m,
 LED version with kit
 G9 LED NEMO (p.269)

| FINISHING | code | structure |
|-------------|------------|-----------|
| white | CRO HWW 55 | ○ |
| polished | CRO HLW 55 | ● |
| black | CRO HNW 55 | ● |
| gold | CRO HGW 55 | ● |
| gold plated | CRO HOW 55 | ● |

CROWN BLACK



CROWN GOLD



CROWN WHITE



CROWN MINOR

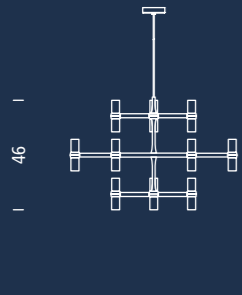

46



Ø77

CROWN MAJOR

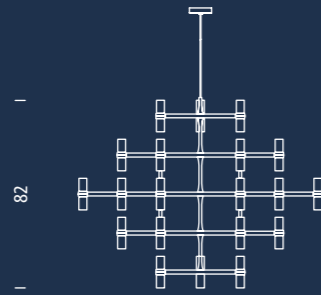

82



Ø115

CROWN MULTI



82



Ø46

CROWN SUMMA

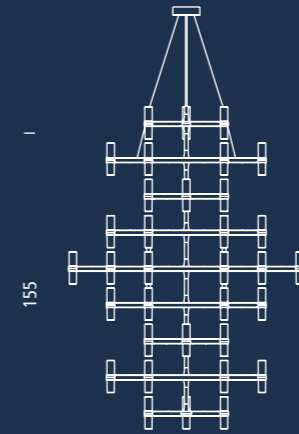

155



Ø115

CROWN MAGNUM

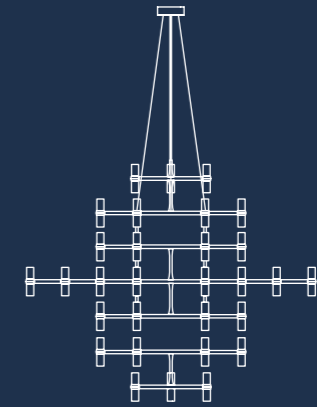

130

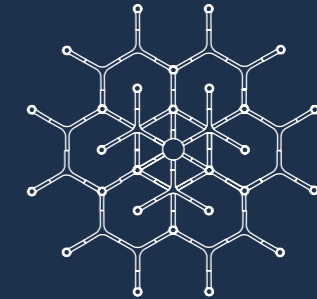

Ø160

CROWN PLANA MEGA



116

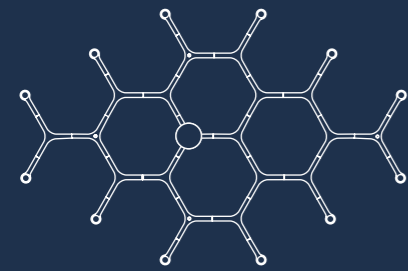

113

172

CROWN PLANA MAJOR

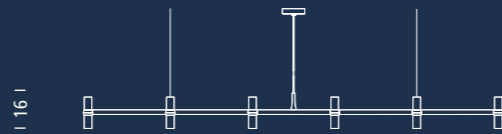

116

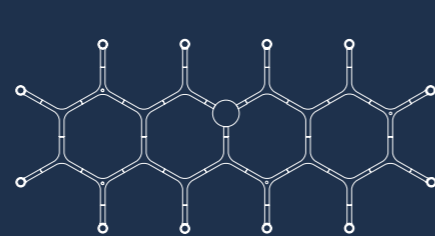

88

186

CROWN PLANA MINOR

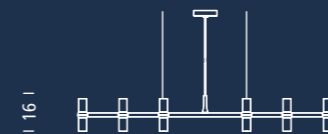

116

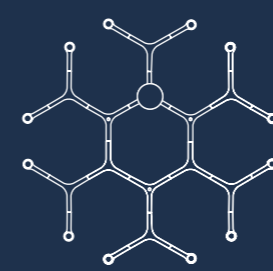

Ø109

CROWN PLANA



116

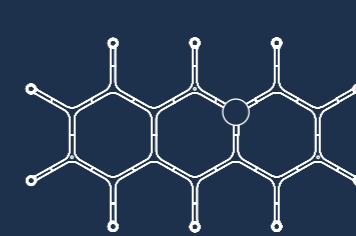

82

142

CROWN PLANA LINEA

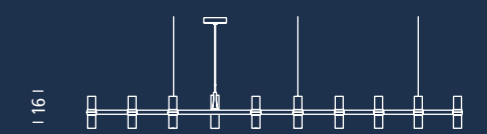

116

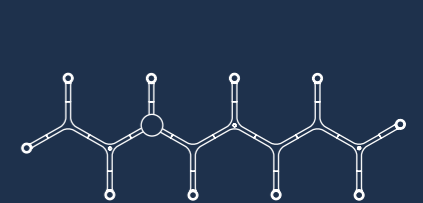

56

168

Lampade da parete, realizzate con una struttura modulare in alluminio pressofuso e bicchierini diffusori in vetro sabbato. La struttura è disponibile in versione alluminio spazzolato lucido, dorato oppure verniciato opaco nei colori bianco, nero o oro.

Wall lamps, with modular structure in die-casted aluminium and sandblasted glass diffusers. Structure in aluminium hand polished glossy or gold plated or painted in matt white, matt black or gold.

Applique, réalisée avec une structure modulaire en aluminium moulé. Diffuseurs en verre sablé. Disponible en aluminium poli à la main, brillant ou or, ou peint en blanc mat, noir mat ou doré.

Wandleuchten mit einer modularen Struktur aus Aluminiumdruckguß und sandgestrahlten Diffusorgläsern. Die Struktur ist glänzend poliert, vergoldet oder in matt weiß, matt schwarz und goldfarben lackiert lieferbar.

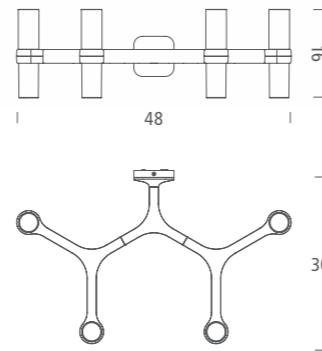
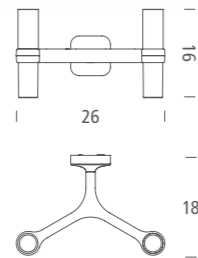

CROWN WALL 2 HALO/LED

| | |
|-----------|---|
| source | halopin G9 QT-14 |
| emission | diffused |
| max power | 2x60W |
| switching | dimnable |
| tension | 110/230V |
| note | cable lenght max 2,5m, LED version with kit G9 LED NEMO (p.269) |

| FINISHING | code | structure |
|-------------|------------|-----------|
| white | CRO HWW 31 | ○ |
| polished | CRO HLW 31 | ● |
| black | CRO HNW 31 | ● |
| gold | CRO HGW 31 | ● |
| gold plated | CRO HOW 31 | ● |

CROWN WALL 4 HALO/LED

| | |
|-----------|---|
| source | halopin G9 QT-14 |
| emission | diffused |
| max power | 4x60W |
| switching | dimnable |
| tension | 110/230V |
| note | cable lenght max 2,5m, LED version with kit G9 LED NEMO (p.269) |

| FINISHING | code | structure |
|-------------|------------|-----------|
| white | CRO HWW 32 | ○ |
| polished | CRO HLW 32 | ● |
| black | CRO HNW 32 | ● |
| gold | CRO HGW 32 | ● |
| gold plated | CRO HOW 32 | ● |

